

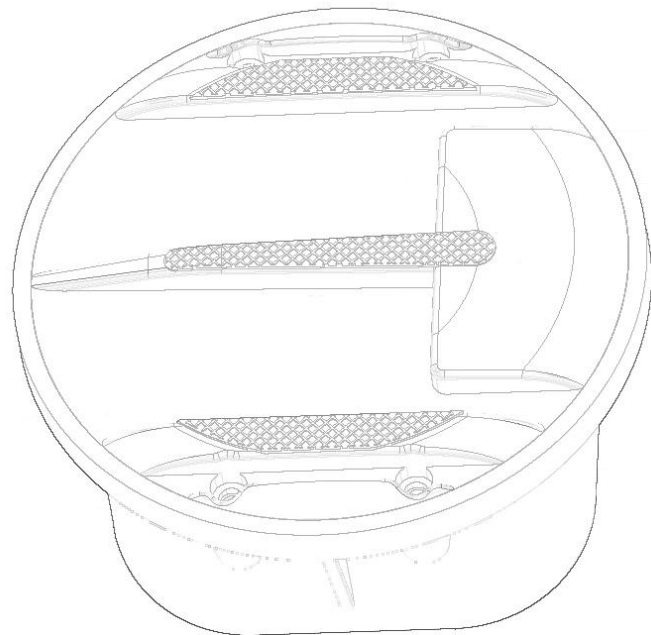

BL-004CA

EVERY LITTLE LIGHT FOR SAFETY



Contents

Contents.....	2
1 Scope.....	3
2 Products Description.....	3
2.1 Features.....	3
2.2 Mechanical.....	3
2.3 Electrical.....	3
2.4 Optical.....	4
3 Structure Diagram.....	4
4 Installation.....	4
4.1 Applicable Place.....	4
4.2 Installation Method.....	5
4.3 Installation Suggestion.....	5

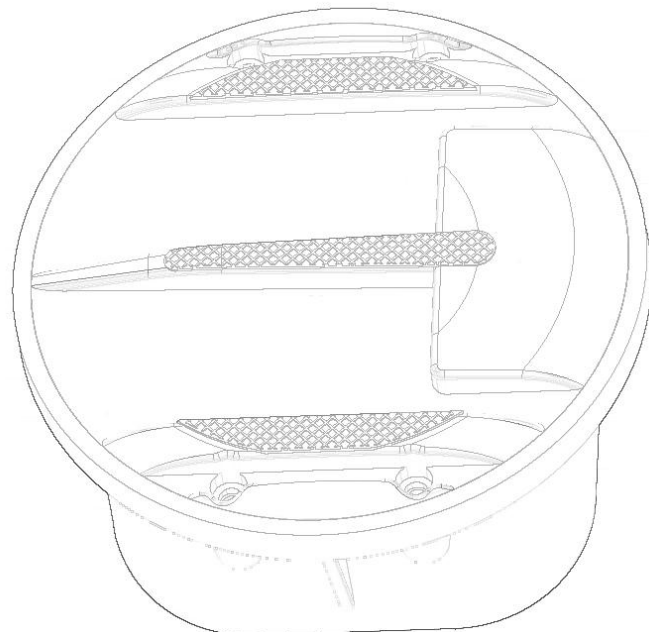

1 Scope

This specification covers the detailed Specification and Performance for the following products listed as below:

2 Products Description

2.1 Features

- 2.1.1 Unidirectional operation.
- 2.1.2 100% waterproof.
- 2.1.3 Low maintenance.
- 2.1.4 Remote controlling.
- 2.1.5 Variable Brightness(Customizable).
- 2.1.6 Variable distance cables.
- 2.1.7 Operation Mode:Always on, Flashing, Sequential flash,Synchronous flash(Optional).
- 2.1.8 Easy replacement:base (fixed in the pavement), main body (removable).
- 2.1.9 Robust construction, suitable for harsh conditions.
- 2.1.10 Possibility of integration with enforcement systems.
- 2.1.11 LEDs protected by polycarbonate window.
- 2.1.12 Use different LED colors in each window(Optional).
- 2.1.13 Outstanding visibility at the day and night.

2.2 Mechanical

- 2.2.1 Product Material: Aluminum
- 2.2.2 LED Protective Cover Material: Polycarbonate Window
- 2.2.3 Mechanical Resistance: 30 Tons Truck
- 2.2.4 Diameter: Ø170mm
- 2.2.5 Product Height(with basement):98.2mm
- 2.2.6 Rising From Road Surface: 8.2mm
- 2.2.7 Installation Depth: 100mm
- 2.2.8 Product Weight(with basement):1430±100g
- 2.2.9 Waterproof level: IP68
- 2.2.10 Operation Mode: Always on, Flashing, Sequential flash,Synchronous flash (Customizable).
- 2.2.11 Work Temperature: -20°C to +80°C

2.3 Electrical

- 2.3.1 Power Supply: DC 12V or DC 24V
- 2.3.2 Power Consumption: 432mw
- 2.3.3 Current Consumption: 36mA
- 2.3.4 Cable Connection: Red Wire (+) Black Wire (-)

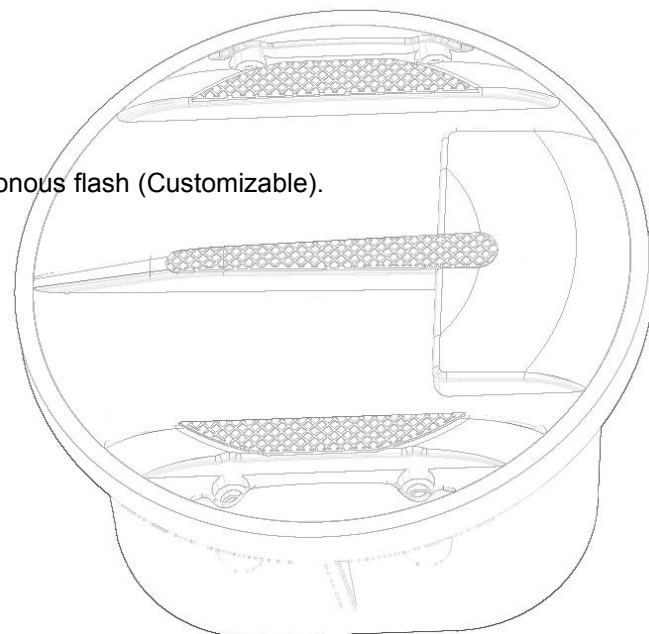

2.4 Optical

2.4.1 LED Qty:

8 LEDs

2.4.2 LED Type:

Φ5mm

2.4.3 Viewing Angle:

15° 15° 15° 15° 15°

2.4.4 Color Optional:

Red Yellow Green Blue White

2.4.5 LED Wavelength:

616-618nm 588-590nm 517-520nm 460-462nm /

2.4.5 Brightness Intensity:

25000-30000mcd 25000-30000mcd 15000-20000mcd 16000-18000mcd 16000-18000mcd

2.4.6 LED Configuration:

Unidirectional

2.4.7 LED Brightness:

Variable Brightness(Customizable)

2.4.8 Visual Distance:

500M

3 Structure Diagram

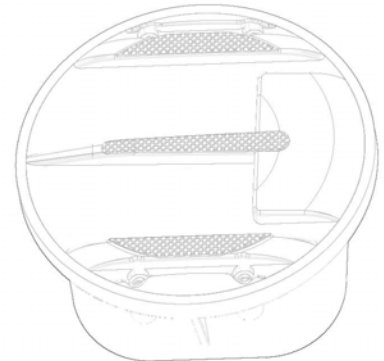
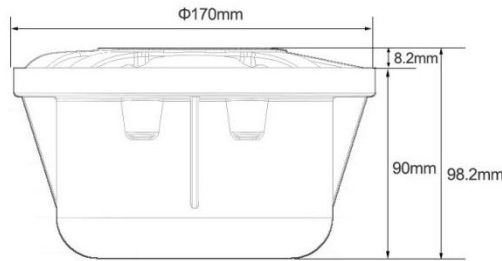
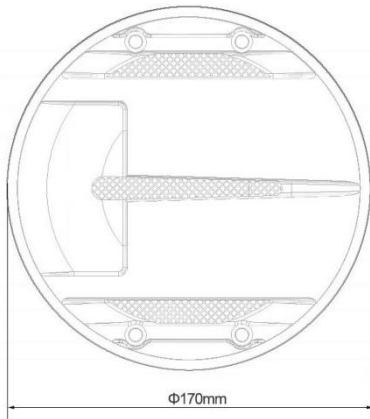

4 Installation

4.1 Applicable Place

- Highway
- Greenways
- Pedestrian walkway
- Delineation of roads
- Motorways

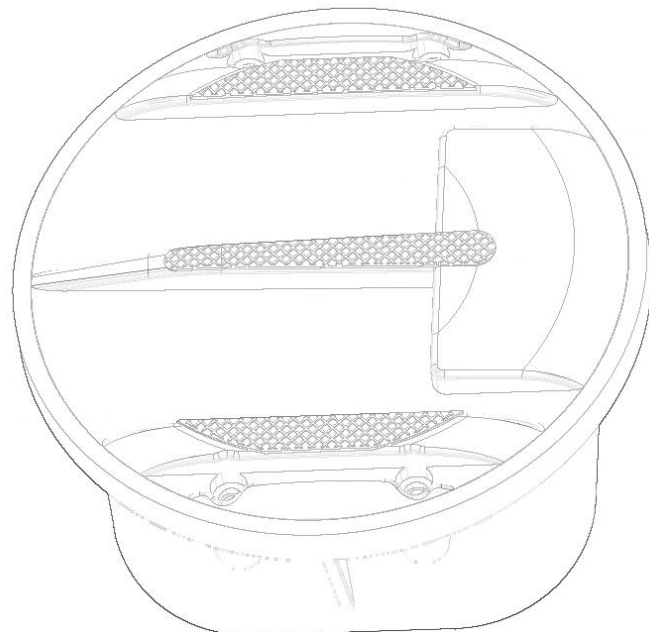

4.2 Installation Method

- 4.2.1 Isolate all power before commencing installation.
- 4.2.2 The road surface should be level and even ,any repair to the surface should be conducted prior to installation.
- 4.2.3 Cut a channel approximately 15mm wide to a depth of 60mm,ensure the channel is cleaned of all debris.
- 4.2.4 Boring a specific size hole at the placement location of the road stud that should be Ø170mm*100mm.
- 4.2.5 Use a blowtorch to dry any dampness from the holes,failure to do so may result in the adhesive glue not bonding correctly.
- 4.2.6 Insert the protective rubber padding into the channel once it has been dried and had time to cool down.
- 4.2.7 Pour the adhesive glue into the hole and locate the road stud so that its lighted side is facing towards to drivers.
- 4.2.8 Inspect studs 2 hours after installation and re-adjust if there has any movement.
- 4.2.9 Inspect after 4 hours and check that all studs are firmly located and show no signs of movement, if all have set correctly re-instate power.

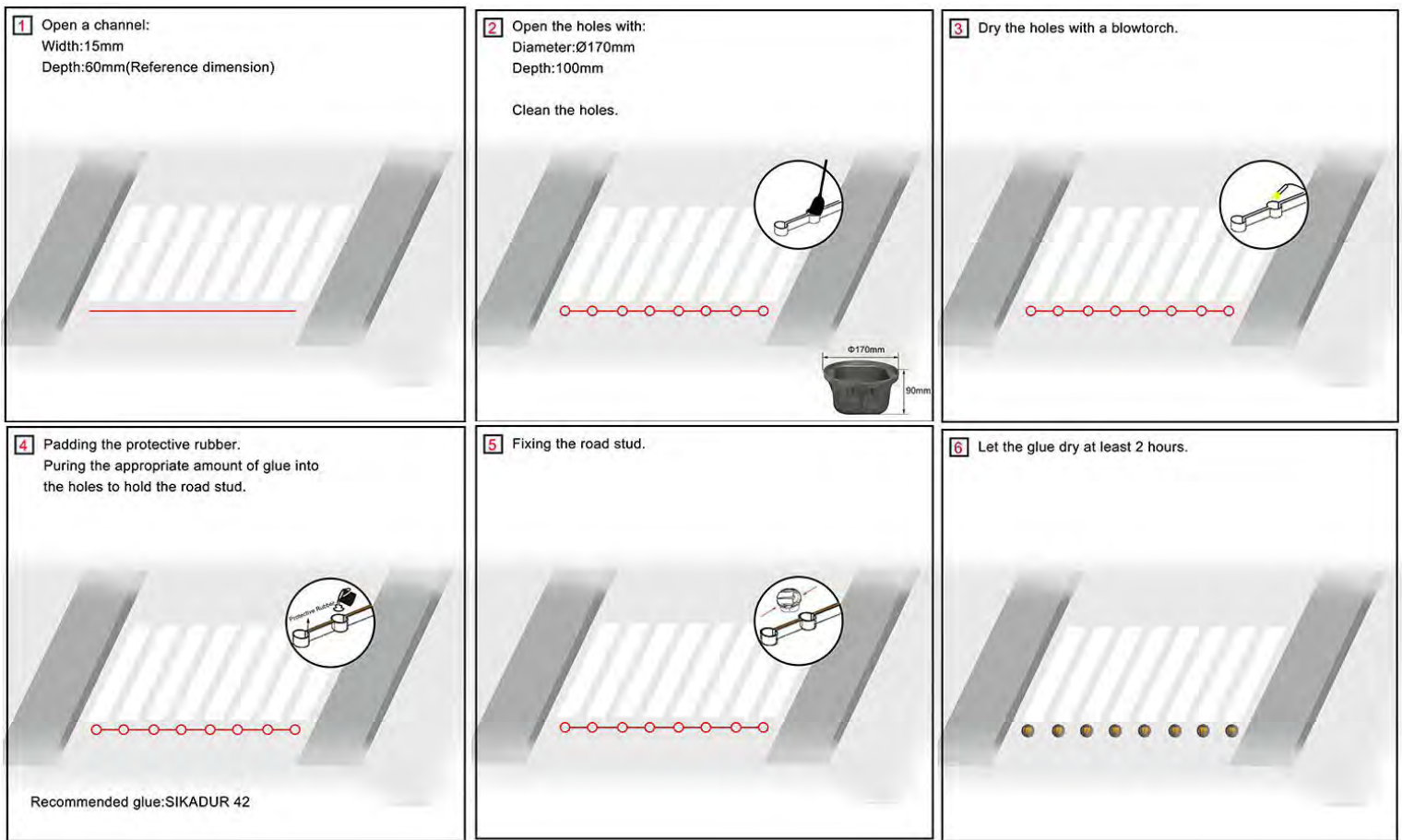

4.3 Installation Suggestion

- 4.3.1 Installation Depth: 100mm
- 4.3.2 Maintenance Method: Base (fixed in the pavement), Main body (removable).
- 4.3.3 Other: Ensure any water is removed prior to commencing maintenance.
Use the epoxy supplied for best result.

